



PS E-Series PS B-Series PS 16W

**Comprehensive Design of Mast
Versions and Lift Capacities
for Different Demands**

PS16W

INTRODUCTION

The PS E / PS B-Series and PS 16W for medium stacking operations with capacities up to 1200 kg / 1500kg / 1600kg.

The PS16W with wide mast for high residual lift capacities and perfect view through the mast.

The optional foldable platform with sideways protective arms or the maintenance free batteries for low duty applications makes this truck the ideal assistant.

The powerful AC-drive technology and the CAN-Bus tiller reduces maintenance and increase the overall performance.

ADVANTAGES

- Powerful high quality AC drive unit.
- Optional EPS- Electric steering system.
- 3PzS/4PzS battery cells or maintenance free semi-traction batteries.
- On the 1600kg version with higher battery capacity for longer autonomous operations.
- Different mast versions available.
- Robust and ergonomic design with various storage areas.
- Optional foldable platform with protective arms.



Powerful high quality AC drive unit ensures high performance and low maintenance.

Optional EPS- Electric steering system.

Ergonomic CAN-BUS tiller, for both left-handed and right handed operators.



Key-switch, emergency switch and battery discharge indicator.



Diverse storage areas for stretch foils, documents or clipboards, etc.



High performance 3PzS (4PzS) DIN-standard battery cells for long operations.



Optional foldable platform with protective arms. The cushioned platforms ensure safety in all travelling conditions.



Foldable platform for higher flexibility in narrow spaces.

Several mast versions available for PS B-Series with different lifting heights.



PSE-series PSB-series

Electric Stacker

Mast table PS B12 / PS E12 / PS B15

Designation	Lowered mast height h1 (mm)	Free lift height h2 (mm)	Lift height h3 (mm)	Lift-fork height h3+h13 (mm)	Extended mast height h4 (mm)
PS B12					
One-stage mast	1976	1519	1519	1600	1976
Two-stage mast	1796	120	2519	2600	2996
	1946	120	2819	2900	3296
	2096	120	3119	3200	3596
Two-stage mast FFL (Full-Free-Lift)	1946	1484	2819	2900	3281
	2096	1634	3119	3200	3581
PS E12					
One-stage mast	1976	1519	1519	1600	1976
Two-stage mast	1796	120	2519	2600	2996
	1946	120	2819	2900	3296
Two-stage mast FFL (Full-Free-Lift)	1946	1484	2418	2900	3281
PS B15					
Two-stage mast	1946	150	2900	2900	3281
Two-stage mast FFL (Full-Free-Lift)	1946	1484	2900	2900	3281
Three-stage mast	1726	—	3400	3400	1939
Three-stage mast FFL (Full-Free-Lift)	1726	1120	3400	3400	3925

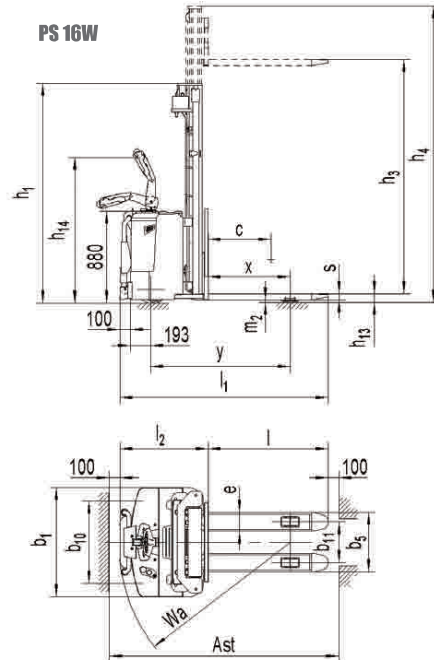
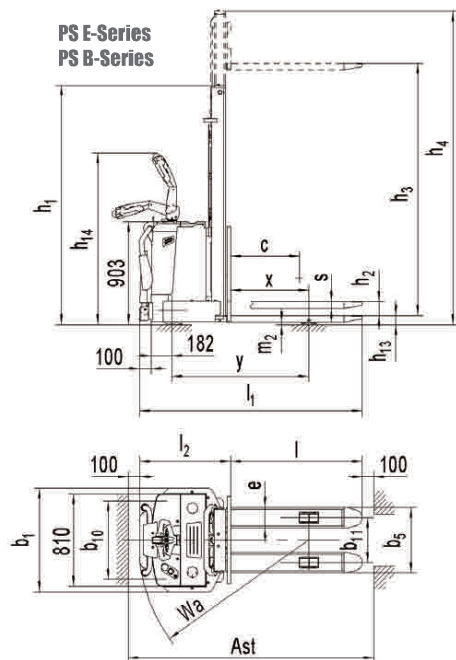

Type sheet for industrial truck acc. to VDI 2198 1100=2.2LB 1100=25.4MM

Distinguishing mark	1.2	Manufacturer's type designation	PS E12 ¹⁾ PS B12 PS B15 PS 16W			
			Battery		Battery	
Distinguishing mark	1.3	Power (battery ,diesel, petrol gas,manual)	Pedestrian		Pedestrian(stand)	
	1.4	Operator type	Pedestrian		Pedestrian(stand)	
	1.5	Load Capacity / rated load	Q(t)	1.2	1.5	1.6
	1.6	Load centre distance	c(mm)	600		600
	1.8	Load distance ,centre of drive axle to fork	x(mm)	684		784
	1.9	Wheelbase	Y(mm)	1196	1235	1336
Weight	2.1	Service weight	kg	765	960	1035
	2.2	Axle loading, laden front/rear	kg	685/1290	830/1330	880/1655
	2.3	Axle loading, unladen front/rear	kg	585/180	730/230	780/255
Tyres, chassis	3.1	Tires	Polyurethane (PU)			Polyurethane (PU)
	3.2	Tire size, front	Ø x w (mm)	Ø 252 x 88		Ø 252 x 88
	3.3	Tire size, rear	Ø x w (mm)	Ø 80 x 70		Ø 80 x 70
	3.4	Additional wheels(dimensions)	Ø x w (mm)	Ø 150 x 54		Ø 150 x 54
	3.5	Wheels, number front/rear(x=driven wheels)		1x+2 / 4		1x+2 / 4
	3.6	Tread, front	b10mm	686		790
	3.7	Tread, rear	b11 (mm)	390/505		390/505
Dimensions	4.2	Lowered mast height	h1 (mm)	1946	2096	1946
	4.3	Free Lift height	h2 (mm)	120		150
	4.4	Lift	h3 (mm)	2819 ²⁾	3119 ³⁾	2819 ⁴⁾
	4.5	Extended mast height	h4 (mm)	3296	3596	3281
	4.9	Height of tiller in drive position min./ max.	h14mm	985/ 1420		961/ 1396
	4.15	Height, lowered	h13mm	81		85
	4.19	Overall length	l1(mm)	1846	1846 / 1946	1893/1983
	4.20	Length to face of forks	l2(mm)	695	695/795	733/833
	4.21	Overall width	b1 (mm)	810	910	
	4.22	Fork dimensions	s/ e/ l(mm)	60/180/1150		
	4.25	Distance between fork- arms	b5 (mm)	570/ 685		570/ 685
	4.32	Ground clearance, centre of wheelbase	m2(mm)	26	21	
	4.33	Aisle width for pallets 1000X1200 crossways	Ast (mm)	2320	2320/2420	2360/2460
	4.34	Aisle width for pallets 800X1200 lengthways	Ast (mm)	2215	2215/2315	2250/2350
	4.35	Turning radius	Wa (mm)	1400	1400/1500	1440/1540
Performance data	5.1	Travel speed, laden/ unladen	km/h	6.0/6.0		6.0 / 6.0
	5.2	Lift speed, laden/ unladen	m/s	0.105/ 0.15		0.10/0.16
	5.3	Lowering speed, laden/ unladen	m/s	0.13/0.11		0.095/0.12
	5.8	Max. gradeability, laden/ unladen	%	6 / 12		6 / 12
5.1	Service brake		Electromagnetic		Electromagnetic	
Electric- Motor	6.1	Drive motor rating S2 60min	kW	1.3		1.3
	6.2	Lift motor rating at S3 15%	kW	2.2	3.0	
	6.3	Battery acc. to DIN43 531/35/36 A,B,C,no		No,not DIN	No,cells 3PZS	
	6.4	Battery voltage, nominal capacity K51)	V/Ah	2 x 12 / 90	24 / 210	
	6.5	Battery weight	kg	65	200	
	6.6	Energy consumption acc. to VDI cycle	kWh/h	1.4	2.5	
Additional data	8.1	Type of drive control		AC- Speed Control		AC- Speed Control
	8.4	sound level at driver's ear acc. to EN 12053	dB(A)	< 70		< 70

1) No platform available, no EPS available 2) Optional 1519mm,2519mm 3) Optional 1519mm, 2519mm, 2819mm, 3519mm 4) Optional 2819mm,3319mm with full free lift(FFL)