

SPAREPARTS LIST

Electric Stacker ECL15B

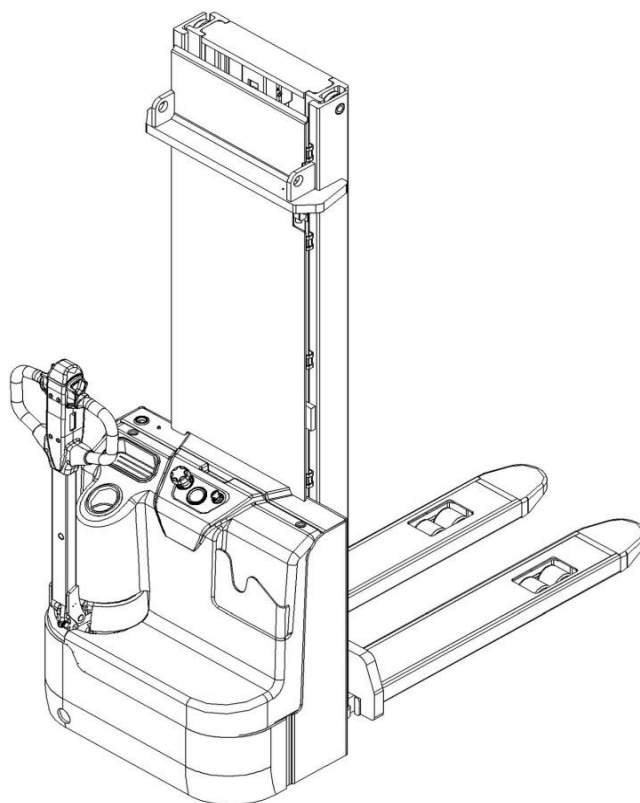

Version 02/2020

From truck identification number:

20190700252

ECL15B-BPT-002-EN

Catalogue

Fig.1 Outline.....	2
Fig.2 Fork carriage (one-stage mast)	3
Fig.3 Fork carriage (two-stage mast).....	4
Fig.4 Load backrest (option)	5
Fig.5 Load roller assembly.....	6
Fig.6 Driving kit	7
Fig.7 Driving wheel components	9
Fig.8 Hydraulic components	10
Fig. 9 Cylinder components	11
Fig. 10 Hydraulic power unit	13
Fig. 11 Side roller components	16
Fig. 12 Panel components	18
Fig. 13 Tiller components.....	20
Fig. 14 Tiller head components	22
Fig. 15 Battery components.....	24
Fig. 16 Mast assembly (Two-stage mast).....	25
Fig. 17 Mast assembly (One-stage mast)	28
Fig. 18 Controller components	30
Fig. 19 Charger components	32
Fig. 20 wiring harness.....	34
Fig. 21 Sticker(for EU)	35
Fig. 22 Sticker(for US)	36
Easy worn parts list.....	37

Fig.1 Outline

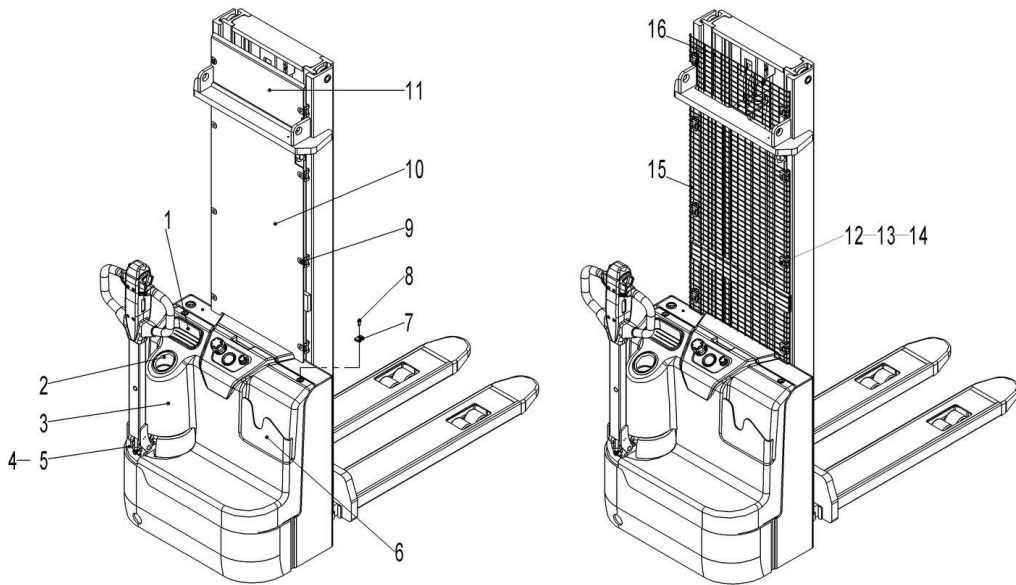

Fig.1 Outline

No.	Art No.	Description	Qty.	Note
1	534721520021	Storage area	1	
2	534721520020	Bottle holder	1	
3	531821520065	Protective cover	1	
4	534721520019	Protective cover	1	
5	910200800011	Screw GB77-M6x10-45H	2	
6	534721520022	File box	1	
7	940400400003	Nut M10-t(3-5)	2	
8	941100100002	Screw M10x55-8.8	2	
9	940400300001	Buckle	8	
10	531821520054	Protective board	1	1600
	531821520060			2000
	531821520039			2900
	531821520038			3200
	531821520030			3600
11	531821520044	Protective board	1	
12	320443020321	Pressing plate	8	
13	910200200038	Screw GB70.1-M6x25-8.8	8	
14	940400400001	Nut M6-t(2-4)	8	
15	531821520061	Mesh	1	1600
	531821520062			2000
	531821520042			2900
	531821520041			3200
	531821520040			3600
16	531821520045	Mesh	1	

Fig.2 Fork carriage (one-stage mast)

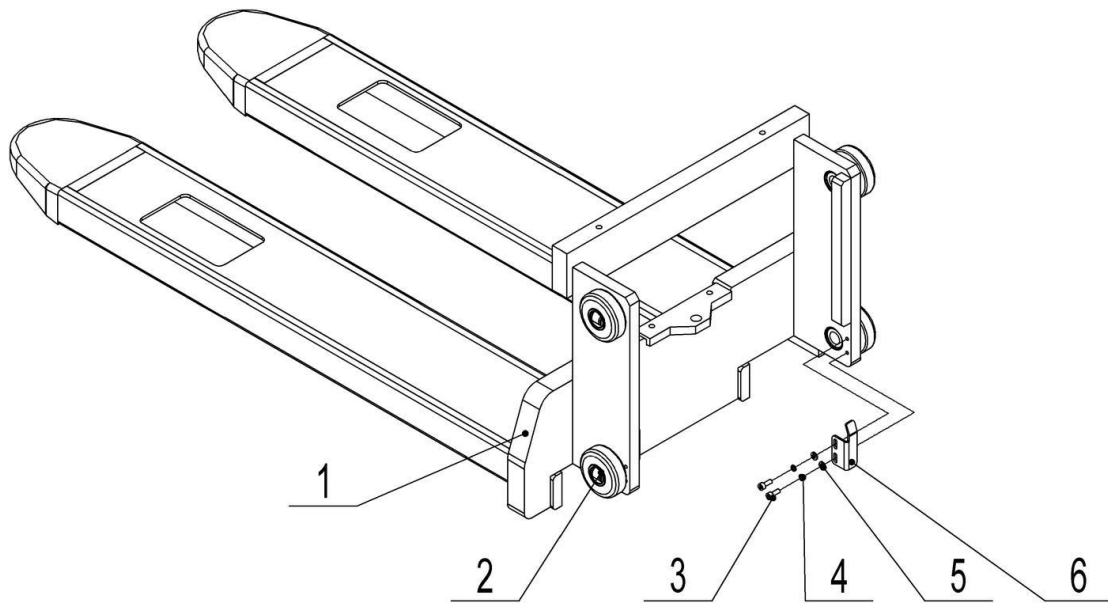

Fig.2 Fork Carriage (one-stage mast)

No.	Art No.	Description	Qty.	Note
1	531838010002	Fork carriage (one-stage mast)	1	570x1150
	531838010003			685x1150
2	940200300008	Roller Φ78.3-range=52.5-56.5	4	
3	910200200035	Screw GB70.1-M6x16-8.8	2	
4	910400500005	Washer GB93-6	2	
5	910400100005	Washer GB97.1-6-200HV	2	
6	531838020010	Limit board	1	

Fig.3 Fork carriage (two-stage mast)

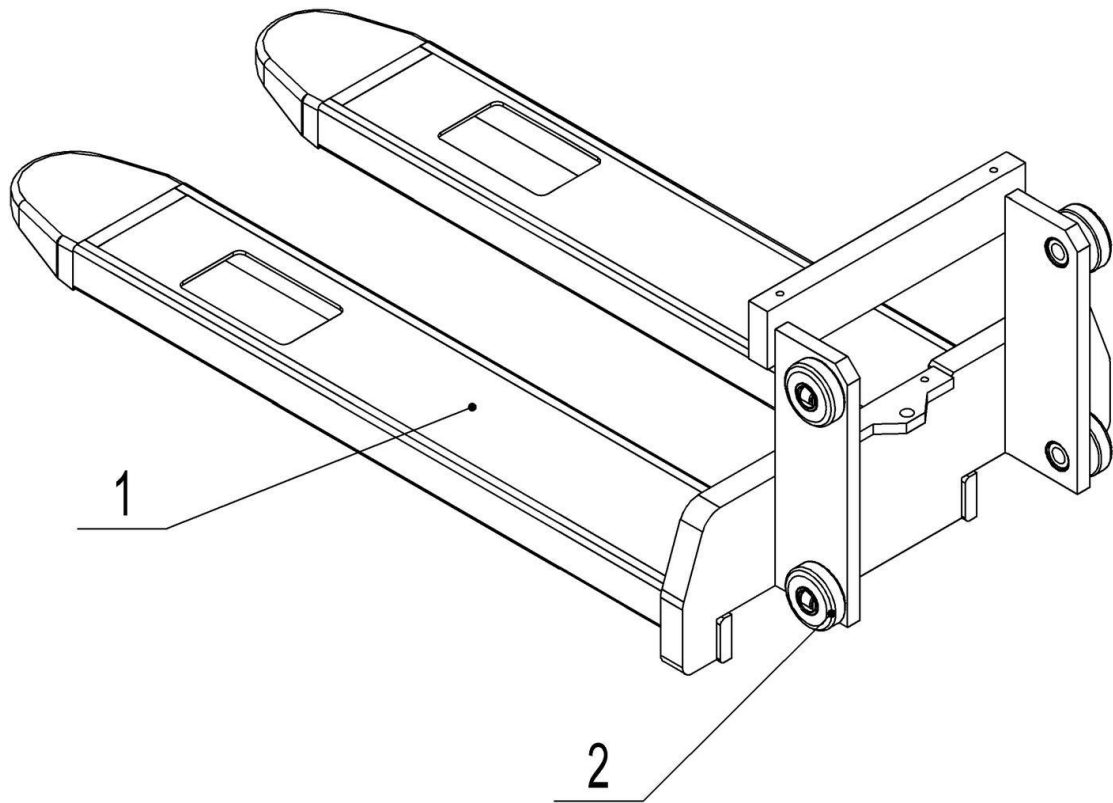

Fig.3 Fork Carriage (two-stage mast)

No.	Art No.	Description	Qty.	Note
1	531838010000	Fork carriage (two-stage mast)	1	570x1150
	531838010001			685x1150
2	940200300008	Roller Φ 78.3-range=52.5-56.5	4	

Fig.4 Load backrest (option)

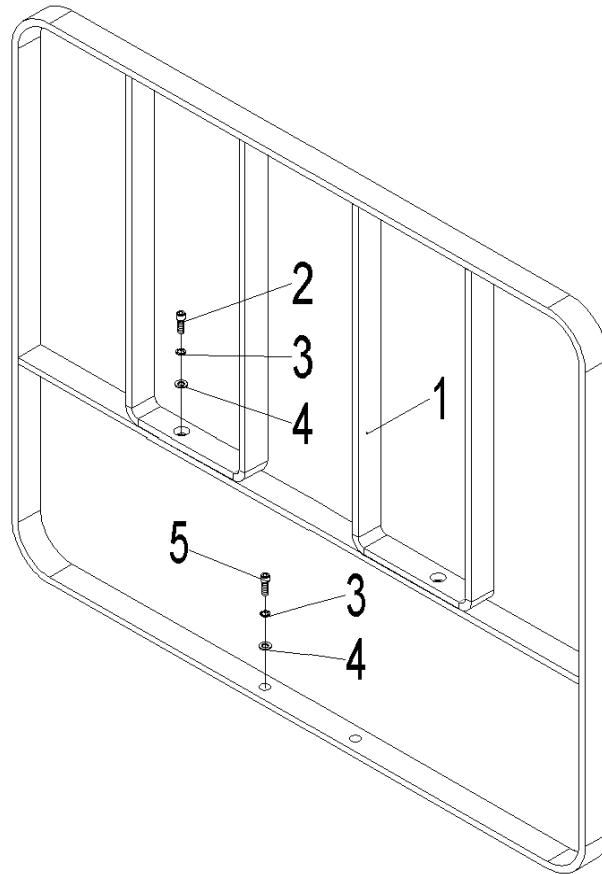

Fig.4 Load Backrest (option)

No.	Art No.	Description	Qty.	Note
1	532640510001	Load backrest welding	1	
2	910200200076	Screw GB70.1-M10x25-8.8	2	
3	910400100007	Washer GB97.1-10-200HV	4	
4	910400500007	Washer GB93-10	4	
5	910200200078	Screw GB70.1-M10x35-8.8	2	

Fig.5 Load roller assembly

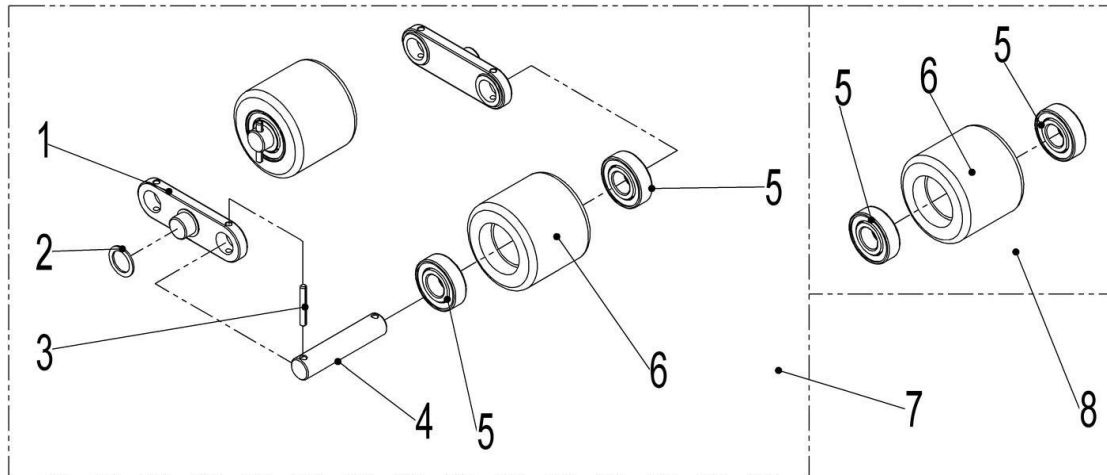

Fig.5 Load Roller Assembly

No.	Art No.	Description	Qty.	Note
1	532617020002	Linking plate	4	
2	940600500012	Washer $\Phi 28 \times \Phi 20 \times 1.5$	4	
3	910600400027	Elastic cylindrical pin 5x35	8	
4	502317020001	Axle $\Phi 20 \times 94$	4	
5	910700200019	Bearing GB276-6204-2RS	8	
6	940300300005	Roller $\Phi 80 \times 70$ (Steel core PU)	4	
7	532698510009	Load roller assembly $\Phi 80 \times 70$	2	
8	502398510002	Roller kits(tandem)	4	

Fig.6 Driving kit

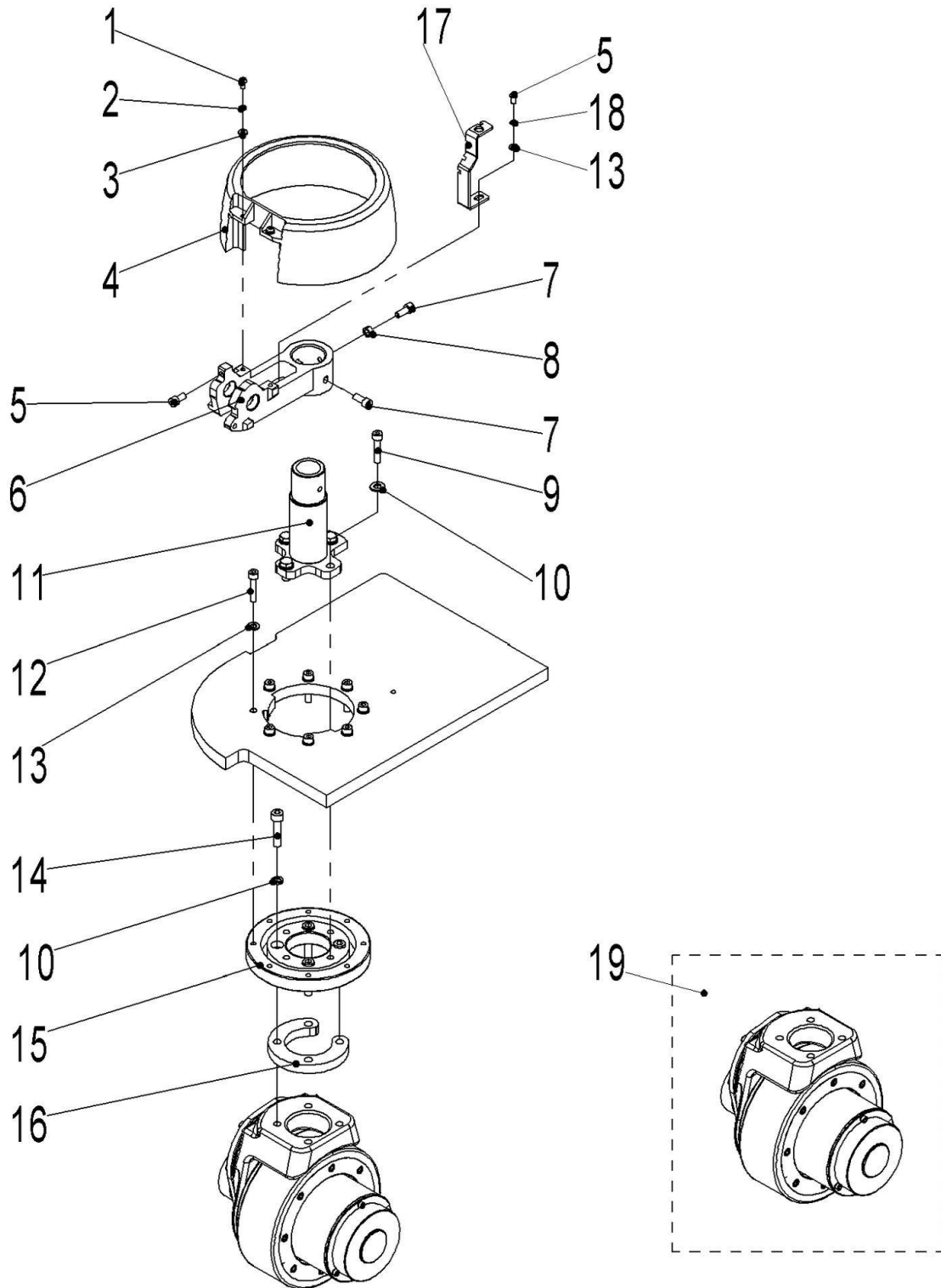

Fig.6 Driving Kit

No.	Art No.	Description	Qty.	Note
1	910200200033	Screw GB70.1-M6x12-8.8	2	
2	910400100005	Washer GB97.1-6-200HV	2	
3	910400500005	Washer GB93-6	2	
4	531813520004	Protective cover (Driving wheel)	1	
5	910200200055	Screw GB70.1-M8x16-8.8	2	
6	531813520003	Tiller base	1	
7	910200200057	Screw GB70.1-M8x20-8.8	3	
8	910300100006	Nut GB6170-M8-10	1	
9	910200200076	Bolt GB70.1-M10x25-8.8	4	
10	910400500007	Washer GB93-10	8	
11	531813510000	Axle welding	1	
12	910200200061	Screw GB70.1-M8x40-8.8	8	
13	910400100006	Washer GB97.1-8-200HV	9	
14	910200200080	Screw GB70.1-M10x45-8.8	4	
15	532213520001	Rotate support	1	
16	531813520005	Linking plate	1	
17	531813520008	Cable holder	1	
18	910400500006	Washer GB93-8	1	
19	508598510003	Driving kit	1	

Fig.7 Driving wheel components

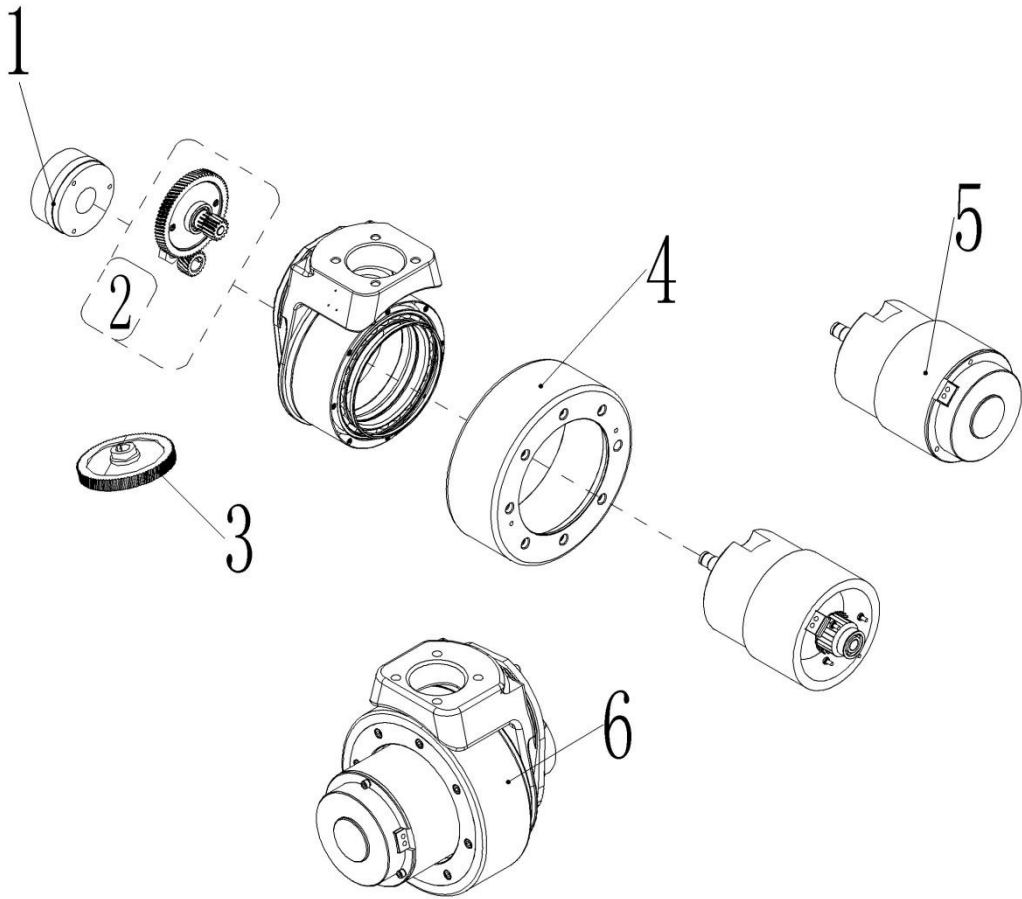

Fig. 7 Driving Wheel Components

No.	Art No.	Description	Qty.	Note
1	508533010010	Brake	1	
2	508098510015	Gear box components	1	
3	508098520004	Big gear ring	1	
4	508098520003	Rubber wheel	1	
5	508598510012	Motor components	1	
6	940900100011	Driving assembly	1	

Fig.8 Hydraulic components

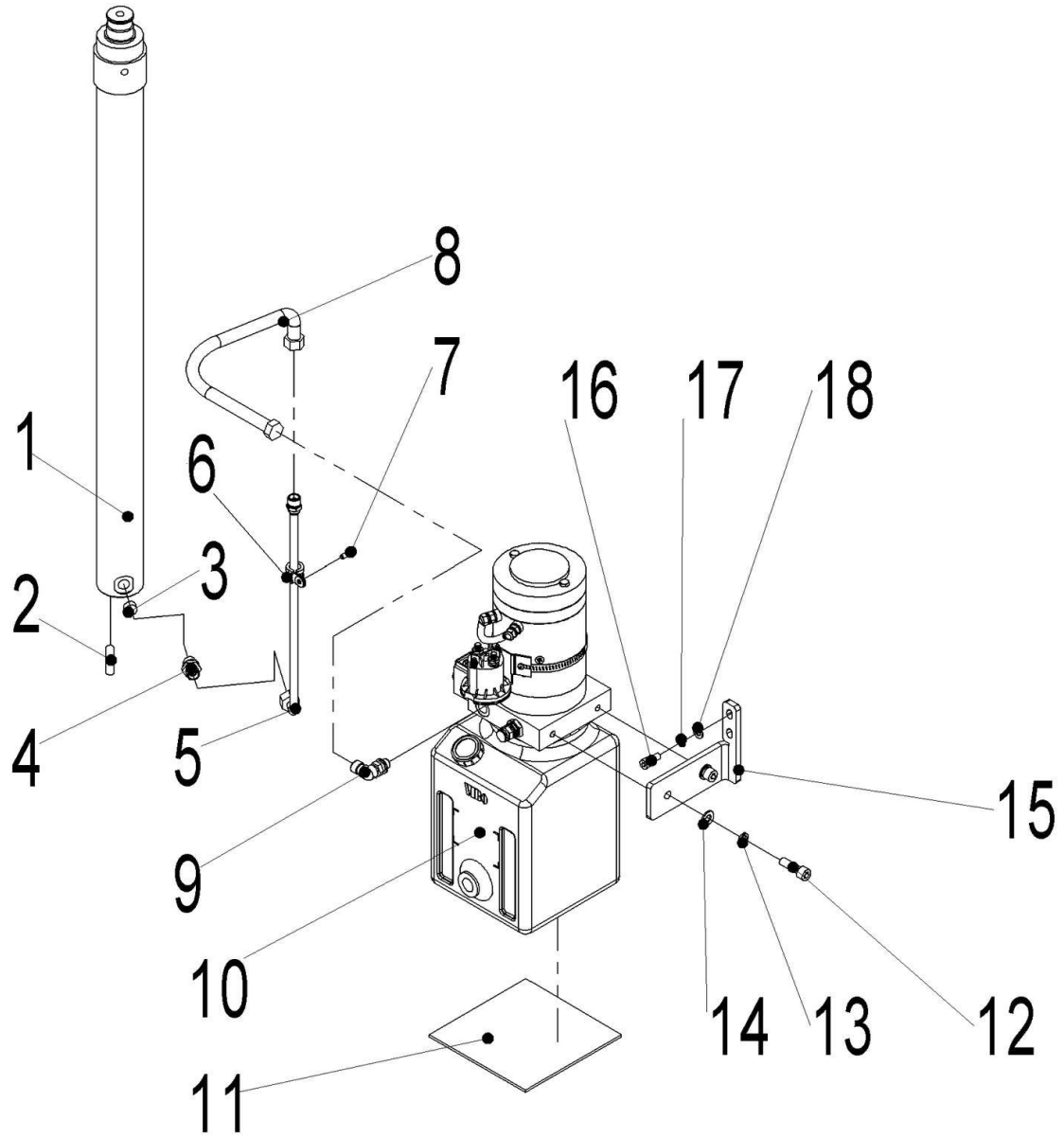

Fig. 8 Hydraulic Components

No.	Art No.	Description	Qty.	Note
1	531821510015	Cylinder components	1	1600
	531821510016			2000
	532644010031			2900
	532644010037			3200
	532644010041			3600
2	910600400020	Elastic cylindrical pin 5x14	1	
3	950600300001	Safety valve M16x1.5	1	
4	950400400003	Joint (Straight)	1	
5	531824010003	Hydraulic tube welding 1	1	
6	951000100001	Clip 12	1	
7	910200200035	Screw GB70.1-M6x16-8.8	1	
8	532424010001	Hydraulic hose assembly	1	
9	950401100008	Joint	1	
10	950900100068	Hydraulic power unit 48V2.2Kw2.0cc	1	
11	531837020012	Damper	1	
12	910200200076	Screw GB70.1-M10x25-8.8	2	
13	910400500007	Washer GB93-10	2	
14	910400100007	Washer GB97.1-10-200HV	2	
15	531824020003	Mounting plate	1	
16	910200200059	Screw GB70.1-M8x30-8.8	2	
17	910400500006	Washer GB93-8	2	
18	910400100006	Washer GB97.1-8-200HV	2	

Fig. 9 Cylinder components

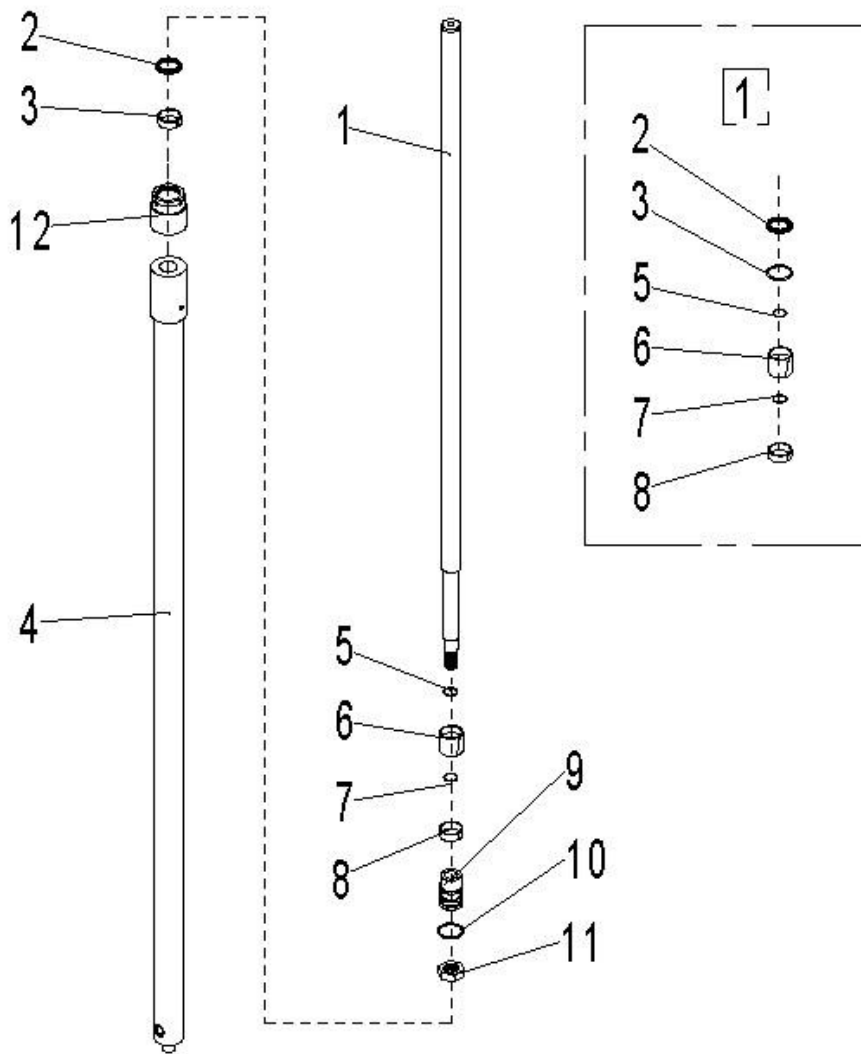

Fig. 9 Cylinder Components

No.	Art No.	Description	Qty.	Note
1	531898520000	Piston rod	1	1600
	531898520001			2000

	532698520039			2900
	532698520007			3200
	532698520008			3600
2	910800400002	Dust ring	1	40x48x5/6.5
3	535398520003	Support ring	1	40X44X10
4	531898520002	Tube	1	1600
	531898520003			2000
	532698520038			2900
	532698520010			3200
	532698520011			3600
5	532698520002	O ring	1	44.4X3.1
6	532698520003	Support ring	1	45X50X10
7	532698520004	O ring	2	24.4X3.1
8	532698520005	Y ring	1	40X50X6/7
9	533598520026	Piston	1	
10	910400500013	Washer	1	24
11	910300200010	Nut	1	M24x1.5
12	533598520001	Nut	1	
□,1	532698510001	Sealing kits	1	

Fig. 10 Hydraulic power unit

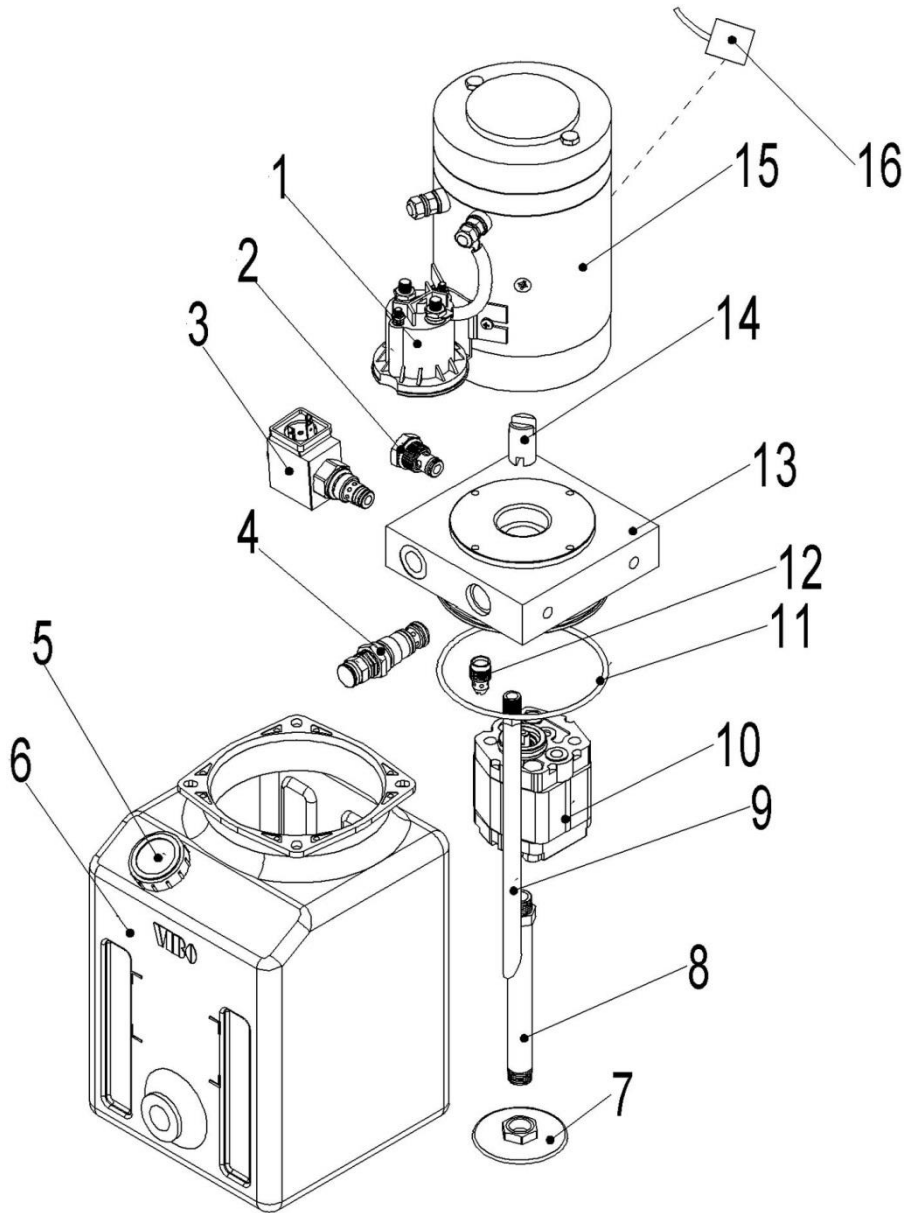

Fig. 10 Hydraulic Power Unit

No.	Art No.	Description	Qty.	Note
1	531898520004	Start on switch	1	DK0148A
2	532098510003	Check valve	1	CV-01
3	531898520005	Electromagnetic valve	1	1

4	402698520018	Overflow valve	1	RV-03
5	531898520006	Oil tank cap	1	FC-04N
6	531898520007	Plastic oil tank	1	6L-TP120A260-V
7	402698520010	Filter mesh	1	FS-03B
8	531898520008	Oil suction hose	1	FP-03V-150
9	531898520009	Oil return hose	1	RU12-230
10	531898520010	Gear pump	1	CBKL-G2200
11	910800100088	O ring	1	112x3.55
12	402698520015	Pressure compensation valve	1	RPCV-02-08
13	531898520011	Valve block	1	CMB1-01-03C
14	531898520012	Coupler	1	ACP-390
15	531898520013	DC motor	1	MD48220
16	531898520014	Carbon brush	4	

Fig. 11 Side roller components

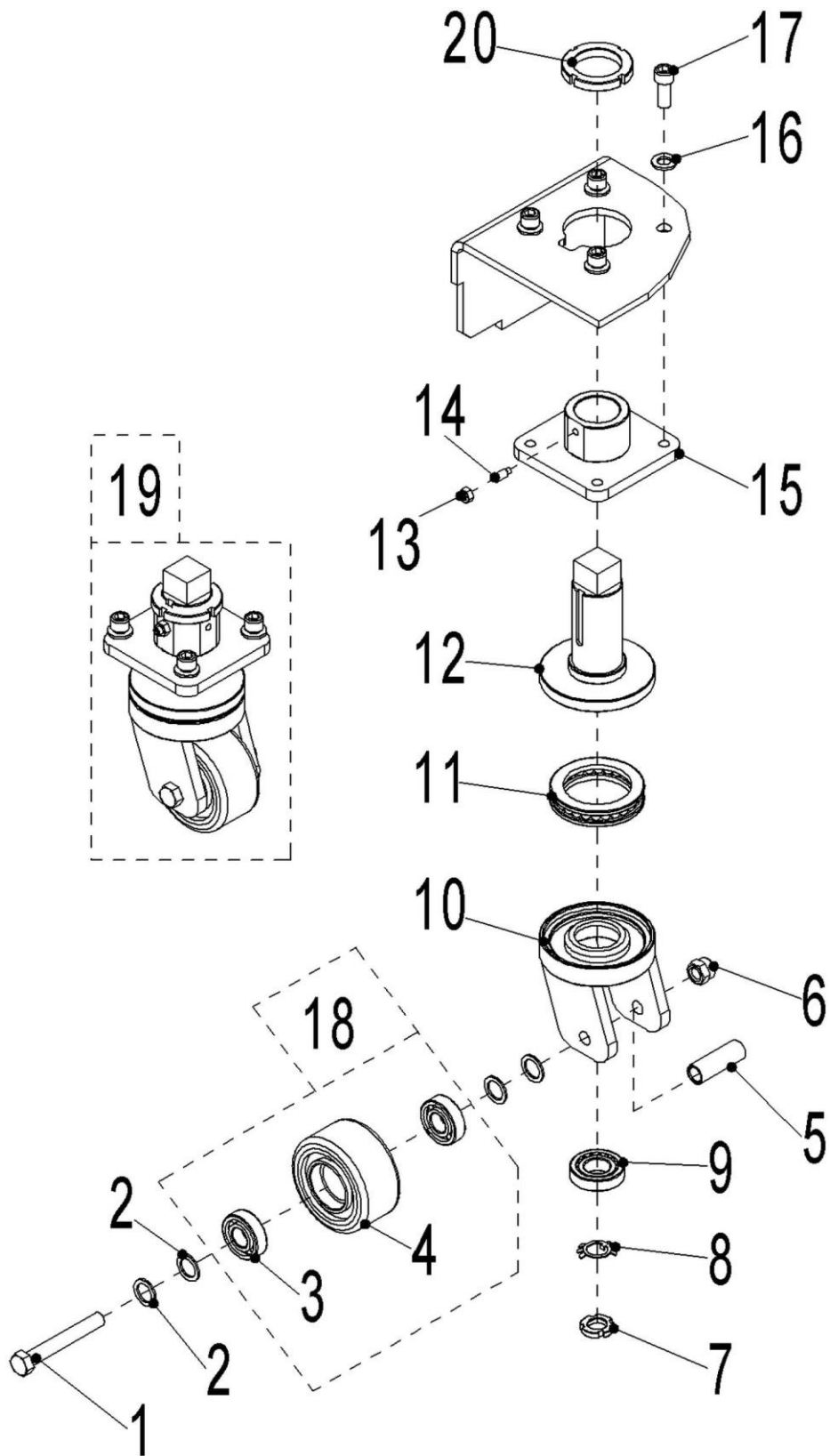

Fig. 11 Side Roller Components

No.	Art No.	Description	Qty.	Note
1	910100100069	Bolt GB5782-M14x100-8.8	1	
2	940600500005	Washer $\Phi 28 \times \Phi 20 \times 2$	4	
3	910700200019	Bearing GB276-6204-2RS	2	
4	940300300030	Roller $\Phi 100 \times 50$ (Steel core PU)	1	
5	532216520006	Bushing	1	
6	910300500007	Nut GB889.1-M14-10	1	
7	910300700008	Nut GB810-M20x1.5	1	
8	910400900002	Washer GB858-20	1	
9	910700600001	Bearing GB297-30205	1	
10	532216510001	Wheel frame welding	1	
11	910700700011	Bearing GB301-51113	1	
12	532216510002	Axle welding	1	
13	910300100006	Nut GB6170-M8-10	1	
14	910201000012	Screw GB79-M8x20-45H	1	
15	532216510003	Fixing base welding	1	
16	910400100008	Washer GB97.1-12-200HV	4	
17	910200200098	Screw GB70.1-M12x30-8.8	4	
18	532298510004	Side roller components	1	
19	532216501001	Side roller assembly	1	
20	941100900004	Nut M48x2-c1B	1	

Fig. 12 Panel components

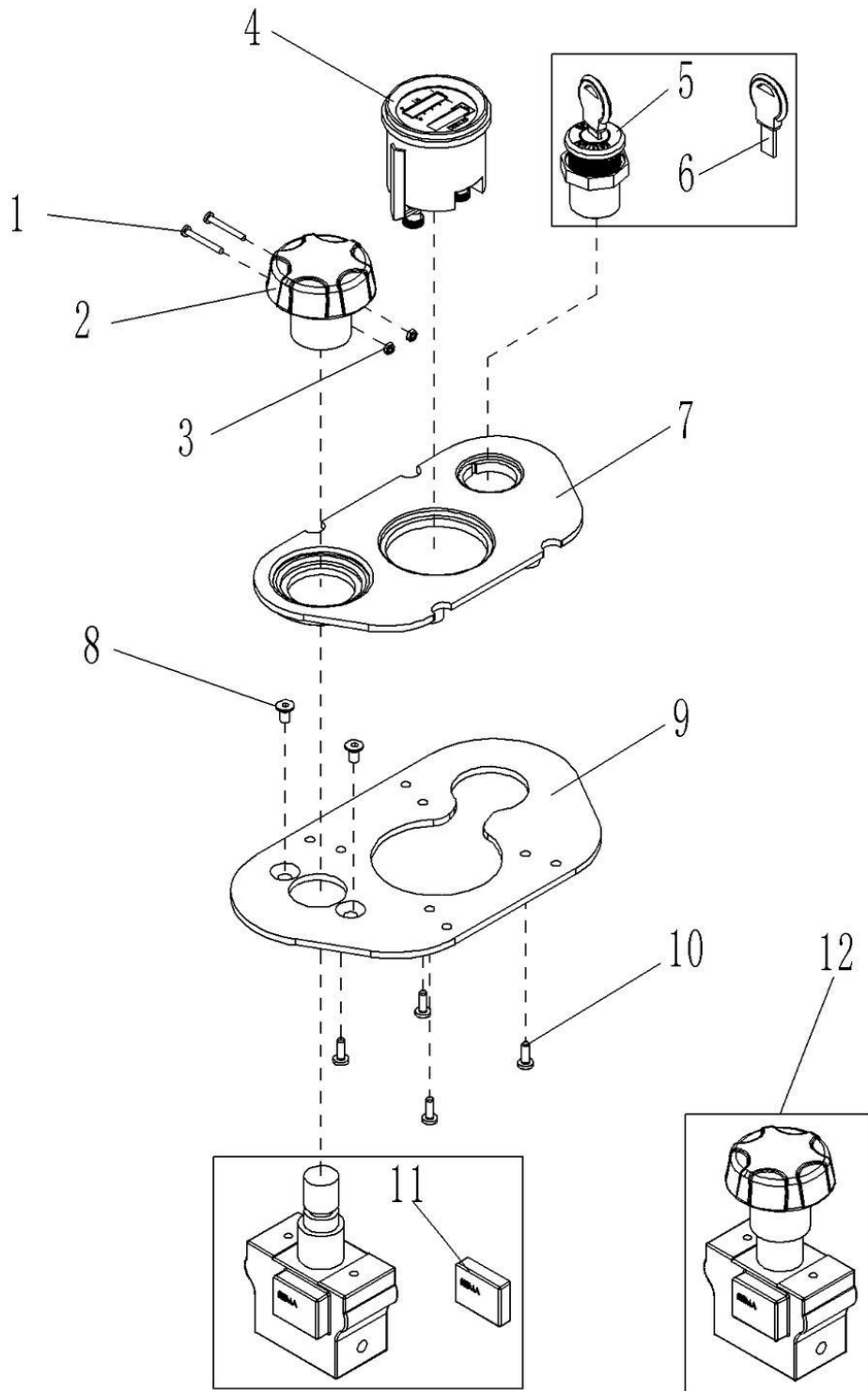

Fig. 12 Panel Components

No.	Art No.	Description	Qty.	Note
1	910200500016	Screw GB818-M3x25-4.8	2	
2	505698520029	Emergency button	1	ZDK32-35
3	910300100002	Nut GB6170-M3-10	2	
4	921100100057	BDI	1	
5	505634010000	Key switch	1	LKS-101A
6	505698520031	Key	1	LKS-101A
7	534710020004	Panel	1	
8	910200400010	Screw GB70.3-M5x10-8.8	2	
9	534710020005	Fixing base	1	
10	910201300001	Screw GB6560-M4x12-A	4	
11	505698520030	Proximity switch	1	ZDK32-350

Fig. 13 Tiller components

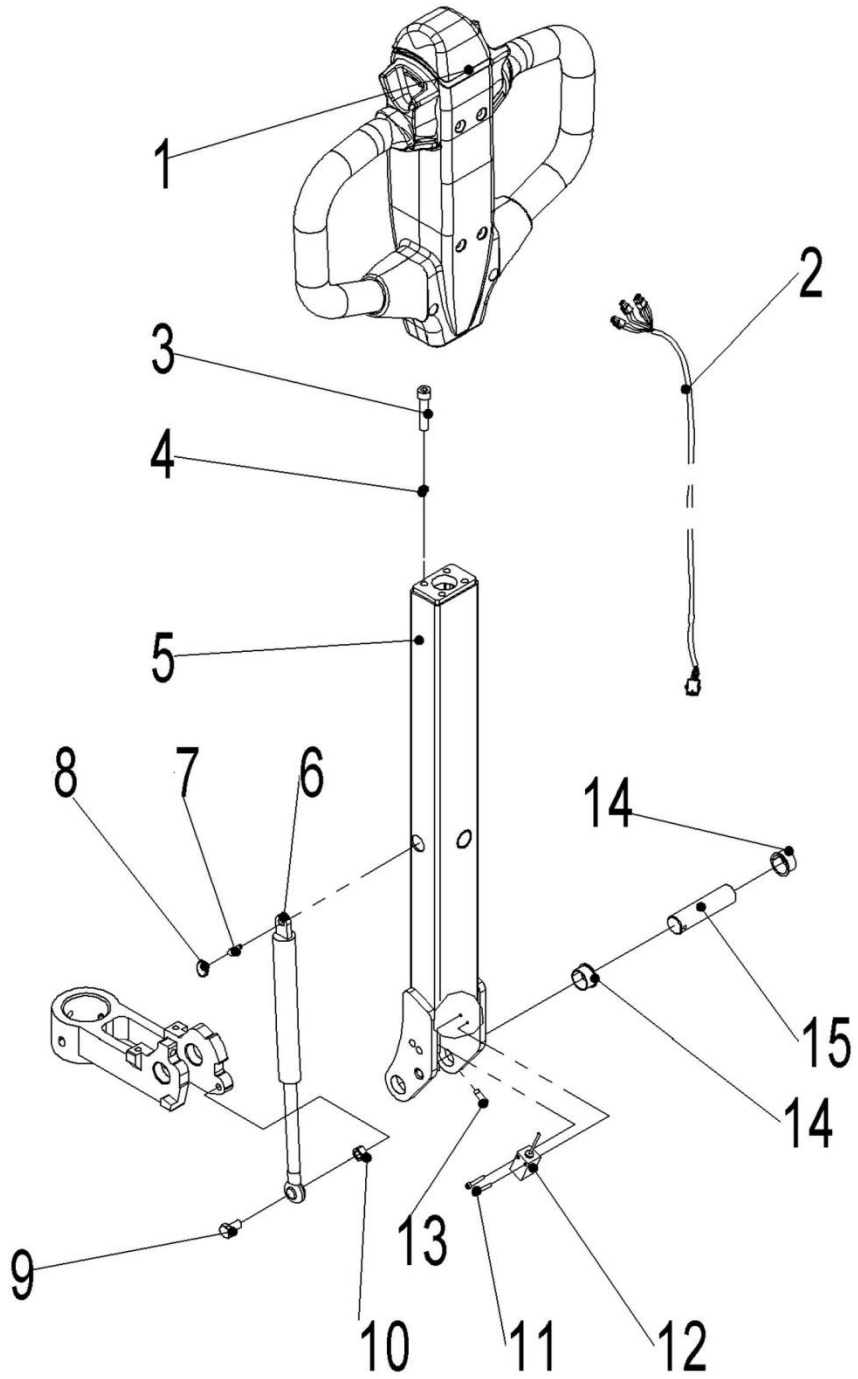

Fig. 13 Tiller Components

No.	Art No.	Description	Qty.	Note
1	534311010004	Tiller head (DTJ07421+lifting+lowering)	1	
2	531833010016	Tiller wiring harness (homemade CAN tiller)	1	
3	910200200058	Screw GB70.1-M8x25-8.8	4	
4	910400500006	Washer GB93-8	4	
5	532011010000	Tiller arm welding	1	
6	940400100043	Air spring	1	
7	941100400001	Screw M8x20-8.8	1	
8	502311020009	Rubber bushing	1	
9	910100300024	Bolt GB5783-M8x30-8.8	1	
10	910300100006	Nut GB6170-M8-10	1	
11	910200500015	Screw GB818-M3x20-4.8	2	
12	920200400033	Proximity switch AZ17M05PK15	1	
13	910600400017	Elastic cylindrical pin GB879.1-4x35	1	
14	940500200005	Bushing (with shoulder) $\Phi 20 \times \Phi 22 \times 12$ -SF-1	2	
15	403511020003	Axle $\Phi 20 \times 78$	1	

Fig. 14 Tiller head components

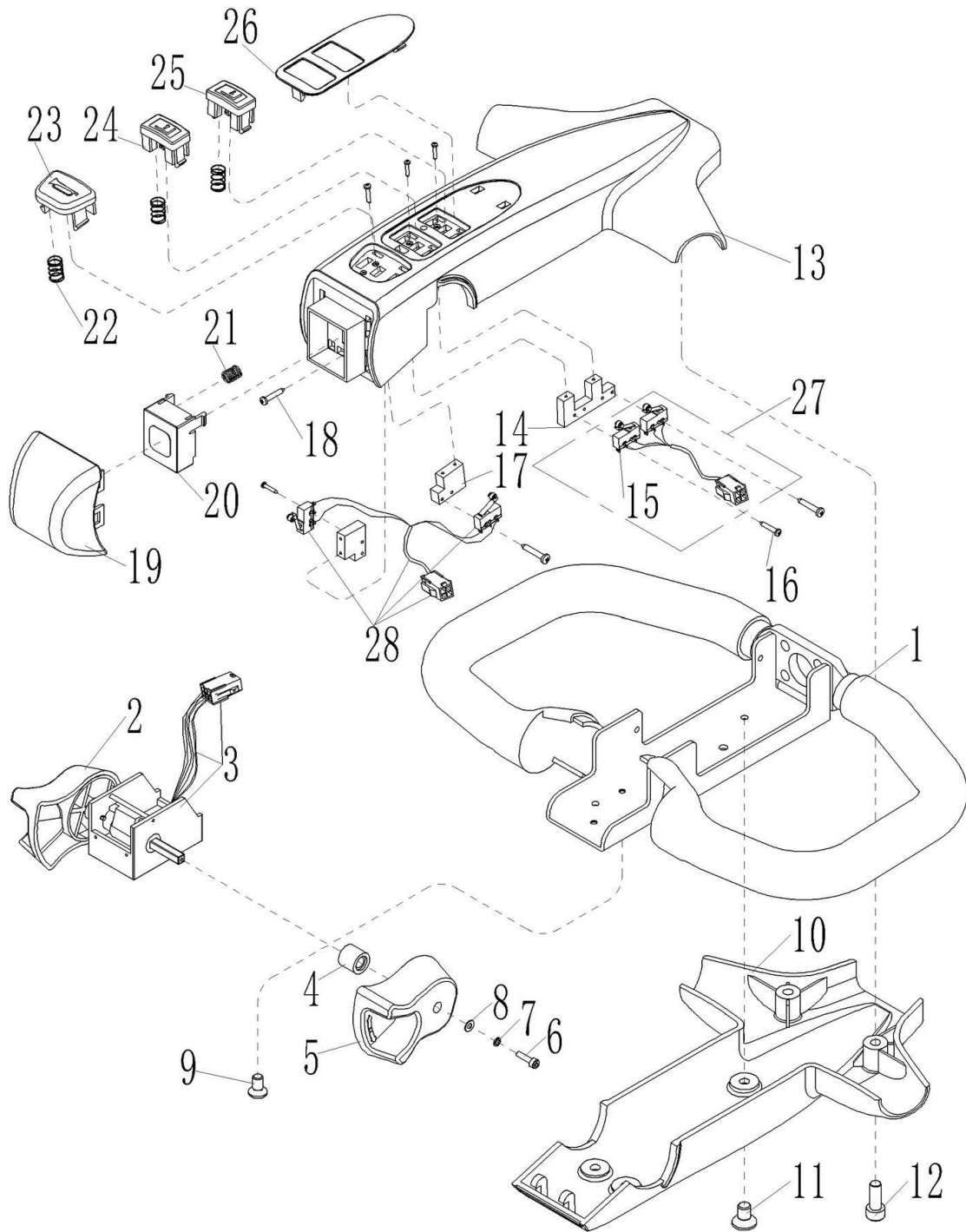

Fig. 14 Tiller Head Components

No.	Art No.	Description	Qty.	Note
1	502311010006	Tiller base	1	
2	502311020011	Left driving knob	1	
3	921700100018	Accelerator	1	DTJ07421
4	502311020013	Bushing	2	
5	502311020012	Right driving knob	1	
6	910200200003	Screw	2	M3x12
7	910400500002	Washer	2	3
8	910400100002	Washer	2	3
9	910200600005	Screw	3	M4x8
10	502311020025	Tiller bottom part	1	
11	910200400015	Screw	4	M6x10
12	910200200035	Screw	2	M6x16
13	502311020024	Tiller upper part	1	
14	502311020015	Micro switch fixing frame	1	
15	920200300002	Micro switch	4	
16	910201400002	Screw	6	ST2.2x13
17	502311020014	Micro switch fixing part	2	
18	910201400001	Screw	8	ST2.2x9.5
19	502311020016	Belly button	1	
20	502311020017	Belly button internal base	1	
21	502311020018	Spring	4	
22	502311020022	Spring	6	
23	502311020019	Horn button	1	
24	502311020020	Lifting button	1	
25	502311020021	Lowering button	1	
26	502311020023	Pin code sticker	1	
27	534311010008	Tiller micro switch components	1	2
28	534311010007	Tiller micro switch components	1	1

Fig. 15 Battery components

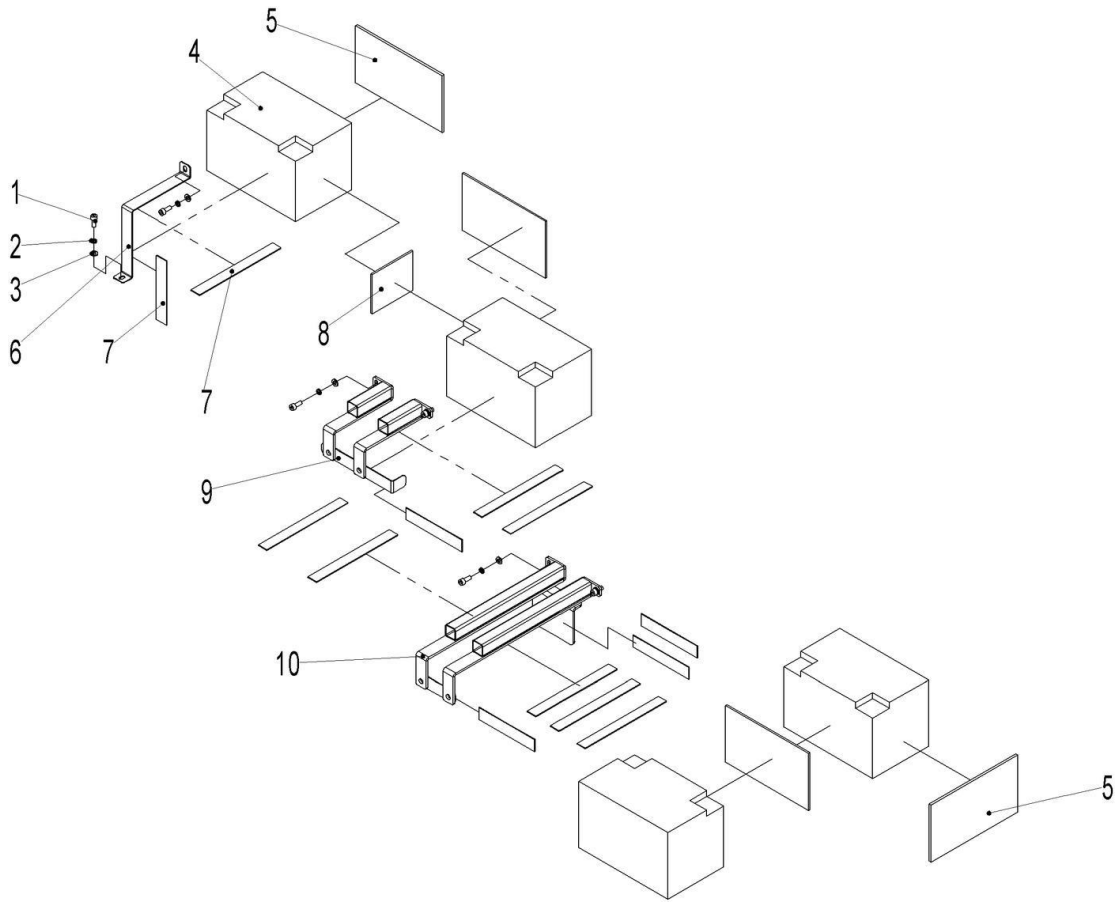

Fig. 15 Battery components

No.	Art No.	Description	Qty.	Note
1	910200200055	Screw GB70.1-M8x16-8.8	6	
2	910400500006	Washer GB93-8	6	
3	910400100006	Washer GB97.1-8-200HV	6	
4	920600100103	Battery 12V64Ah5HR	4	
5	531837020011	Damper 255x145x6	4	
6	531837020000	Fixing plate (Battery)	1	
7	532233020005	Damper 240x25x2	13	
8	532223520002	Damper 120x100x4	1	
9	531837010000	Mounting plate welding (upper)	1	
10	531837010001	Mounting plate welding (down)	1	

Fig. 16 Mast assembly (Two-stage mast)

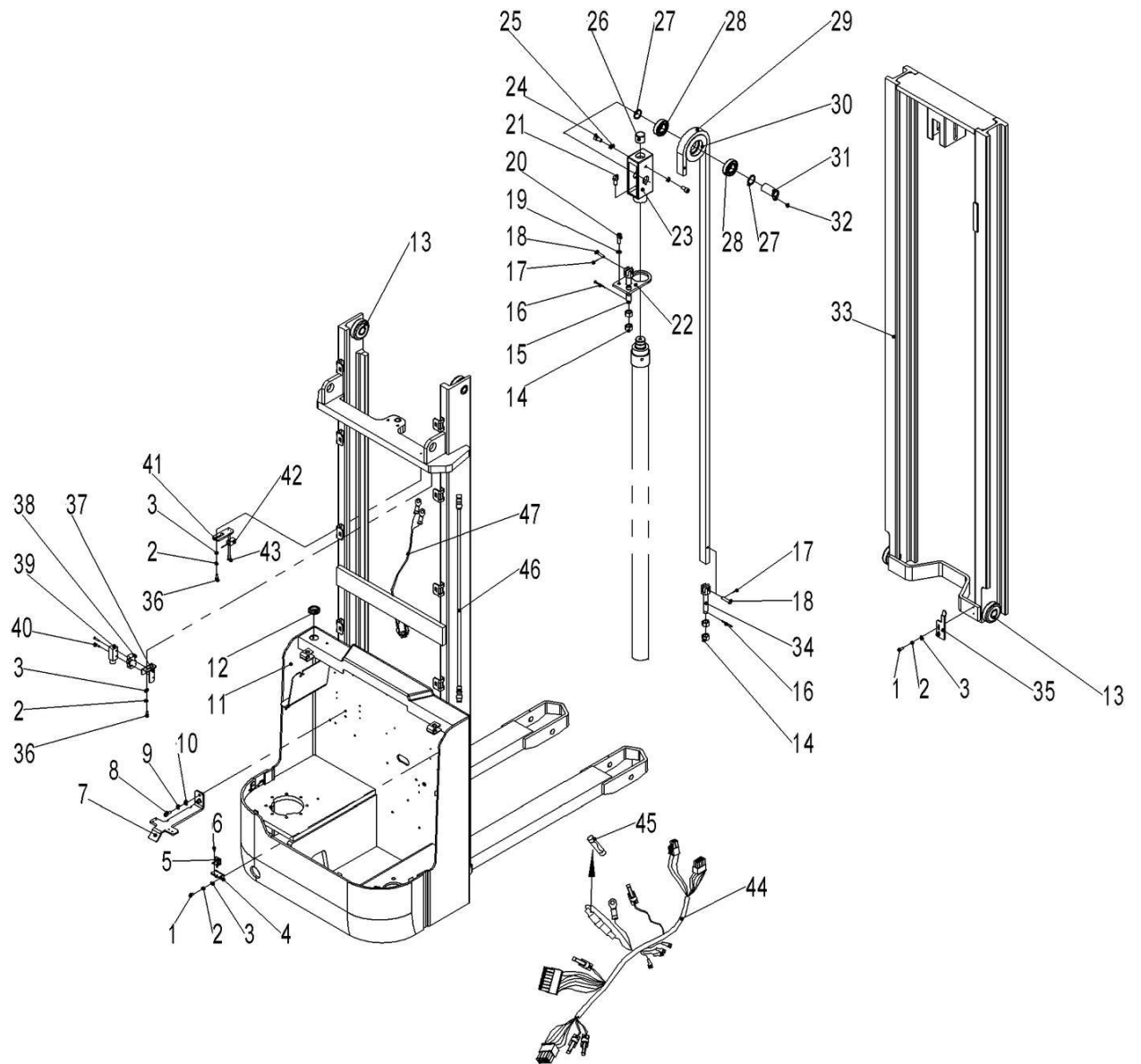

Fig. 16 Mast assembly (Two-stage mast)

No.	Art No.	Description	Qty	Note
1	910200300017	Screw GB70.1-M6x12-8.8	4	
2	910400500005	Washer GB93-6	8	
3	910400100005	Washer GB97.1-6-200HV	8	
4	531821520031	Mounting plate (plug)	1	
5	921300300003	Fixing frame	1	
6	910200500037	Screw GB818-M5x10-4.8	2	
7	531821520026	Cable base	1	
8	910200200054	Screw GB70.1-M8x14-8.8	2	
9	910400500006	Washer GB93-8	2	
10	910400100006	Washer GB97.1-8-200HV	2	
11	531821510001	Chassis welding	1	3600,570x1150
	531821510002			3200,570x1150
	531821510004			2900,570x1150
	531821510006			3600,685x1150
	531821510007			3200,685x1150
	531821510008			2900,685x1150
12	505621520036	Bushing	1	
13	940200300007	Roller Φ 78.3-range=45.3-49.3	4	
14	910300200008	Nut GB6171-M16x1.5-10	4	
15	532643520137	Chain bolt M16x1.5x141	1	
16	910600600037	Split pin GB91-4x40	2	
17	910600600015	Split pin GB91-2x20	2	
18	941100800008	Short axle B8x40-c1B	2	
19	910400500007	Washer GB93-10	2	
20	910200200077	Screw GB70.1-M10x30-8.8	2	
21	910100300049	Bolt GB5783-M12x25-8.8	1	
22	532644020097	Fixing plate (Cylinder)	1	
23	531821520028	Chain pulley frame	1	
24	910200200075	Screw GB70.1-M10x20-8.8	2	
25	910300300005	Nut GB6172.1-M10-05	2	
26	532644020094	Damper Φ 34x30	1	

27	940600500008	Washer $\Phi 37 \times \Phi 31 \times 2$	2	
28	910700200021	Bearing GB276-6206-2RS	2	
29	532644010083	Chain LH1244-91	1	2900
	532644010084	Chain LH1244-99		3200
	532644010085	Chain LH1244-109		3600
30	940200400003	Chain pulley $\Phi 102 \times \Phi 62 \times 29$	1	
31	532644010035	Axle with plate $\Phi 30 \times 57$	1	
32	910200400014	Screw GB70.3-M6x8-8.8	1	
33	531821510005	Inner mast welding	1	2900
	531821510003			3200
	531821510000			3600
34	532644020096	Chain bolt M16x1.5x111	1	
35	531821520001	Limit board	1	
36	910200200035	Screw GB70.1-M6x16-8.8	4	
37	531821520006	Fixing plate (Micro switch)	1	
38	920200300001	Micro switch XZ-15GW22-B	1	
39	920200300008	Micro switch protective cover RZ	1	
40	910200400006	Screw GB70.3-M4x25-8.8	2	
41	531821520007	Fixing plate (speed limit switch)	1	
42	920200400032	Proximity switch AZ17M05PB15	1	
43	910200500015	Screw GB818-M3x20-4.8	2	
44	531833010015	Main control wiring harness (1226BL-4153+ZD)	1	
45	920100300001	Fuse tube 0.5A	1	5x20
46	531833010002	Cable YLS-F-Z307AG-M(1280mm)	1	
47	531833010018	Limit wiring harness	1	

Fig. 17 Mast assembly (One-stage mast)

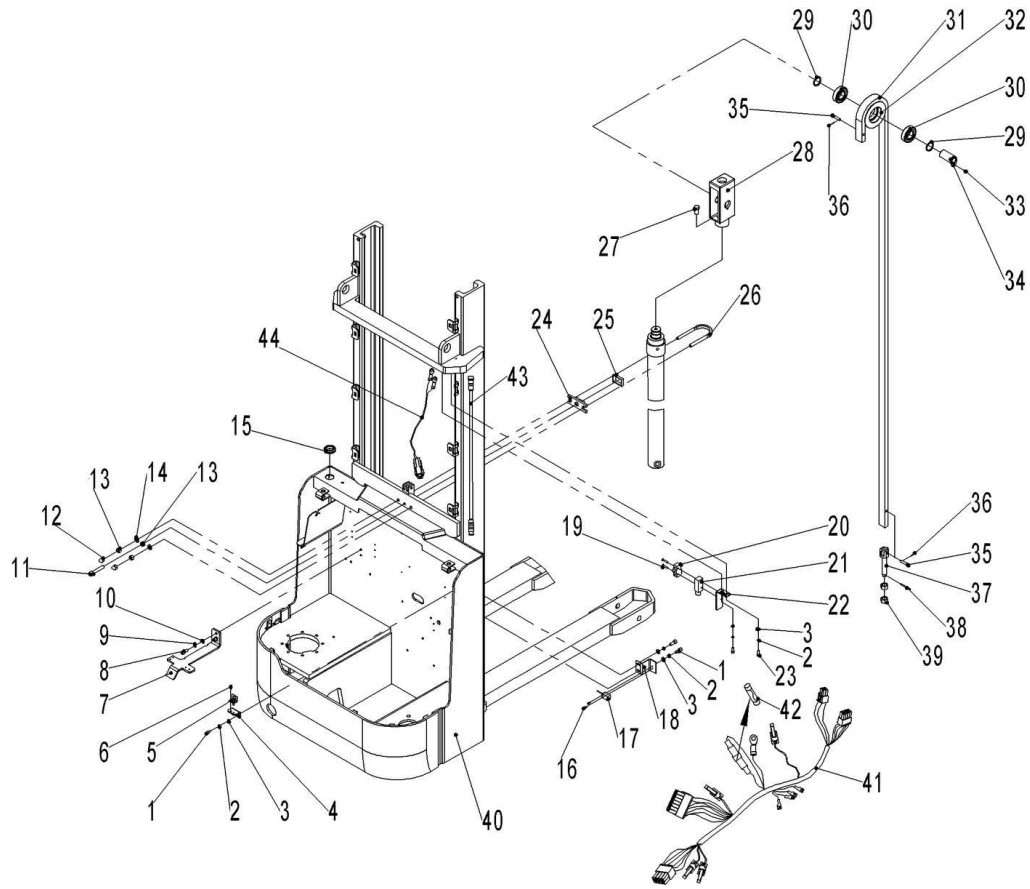

Fig. 17 Mast Assembly (One-stage mast)

No.	Art No.	Description	Qty.	Note
1	910200200033	Screw GB70.1-M6x12-8.8	4	
2	910400500005	Washer GB93-6	6	
3	910400100005	Washer GB97.1-6-200HV	6	
4	531821520031	Mounting plate (plug)	1	
5	921300300003	Plug fixing frame	1	
6	910200500037	Screw GB818-M5x10-4.8	2	
7	531821520026	Cable base	1	
8	910200200054	Screw GB70.1-M8x14-8.8	2	
9	910400500006	Washer GB93-8	2	
10	910400100006	Washer GB97.1-8-200HV	2	
11	910200200083	Screw GB70.1-M10x60-8.8	1	
12	910301000001	Nut GB923-M10-6	2	
13	910300100007	Nut GB6170-M10-10	3	

14	910400100007	Washer GB97.1-10-200HV	2	
15	505621520036	Bushing	1	
16	910200500015	Screw GB818-M3x20-4.8	2	
17	920200400032	Proximity switch AZ17M05PB15	1	
18	532021520053	Fixing plate (Proximity switch)	1	
19	910200400006	Screw GB70.3-M4x25-8.8	2	
20	920200300001	Micro switch XZ-15GW22-B	1	
21	920200300008	Micro switch protective cover RZ	1	
22	531821520055	Fixing plate (Micro switch)	1	
23	910200200035	Screw GB70.1-M6x16-8.8	2	
24	255044020130	Fixing base (Cylinder)	1	
25	255044020129	Protective cover	1	
26	531821520056	Bolt $\Phi 60$	1	
27	910100300049	Bolt GB5783-M12x25-8.8	1	
28	531821520028	Chain pulley frame	1	
29	940600500008	Washer $\Phi 37x\Phi 31x2$	2	
30	910700200021	Bearing GB276-6206-2RS	2	
31	532643510087	Chain LH1244-61	1	1600
	531821510014	Chain LH1244-81		2000
32	940200400003	Chain pulley $\Phi 102x\Phi 62x29$	1	
33	910200400014	Screw GB70.3-M6x8-8.8	1	
34	532644010035	Axle with plate $\Phi 30x57$	1	
35	941100800008	Short axle B8x40-c1B	2	
36	910600600015	Split pin GB91-2x20	2	
37	532644020096	Chain bolt M16x1.5x111	1	1600
	532643520137	Chain bolt M16x1.5x141		2000
38	910600600037	Split pin GB91-4x40	1	
39	910300200008	Nut GB6171-M16x1.5-10	2	
40	531821510011	Chassis welding	1	1600,685x1150
	531821510012			2000,685x1150
	531821510009			1600,570x1150
	531821510010			2000,570x1150
41	531833010015	Main control wiring harness (1226BL-4153+ZD)	1	
42	920100300001	Fuse tube 0.5A	1	5x20
43	531833010002	Cable YLS-F-Z307AG-M(1280mm)	1	
44	531833010018	Limit wiring harness	1	

Fig. 18 Controller components

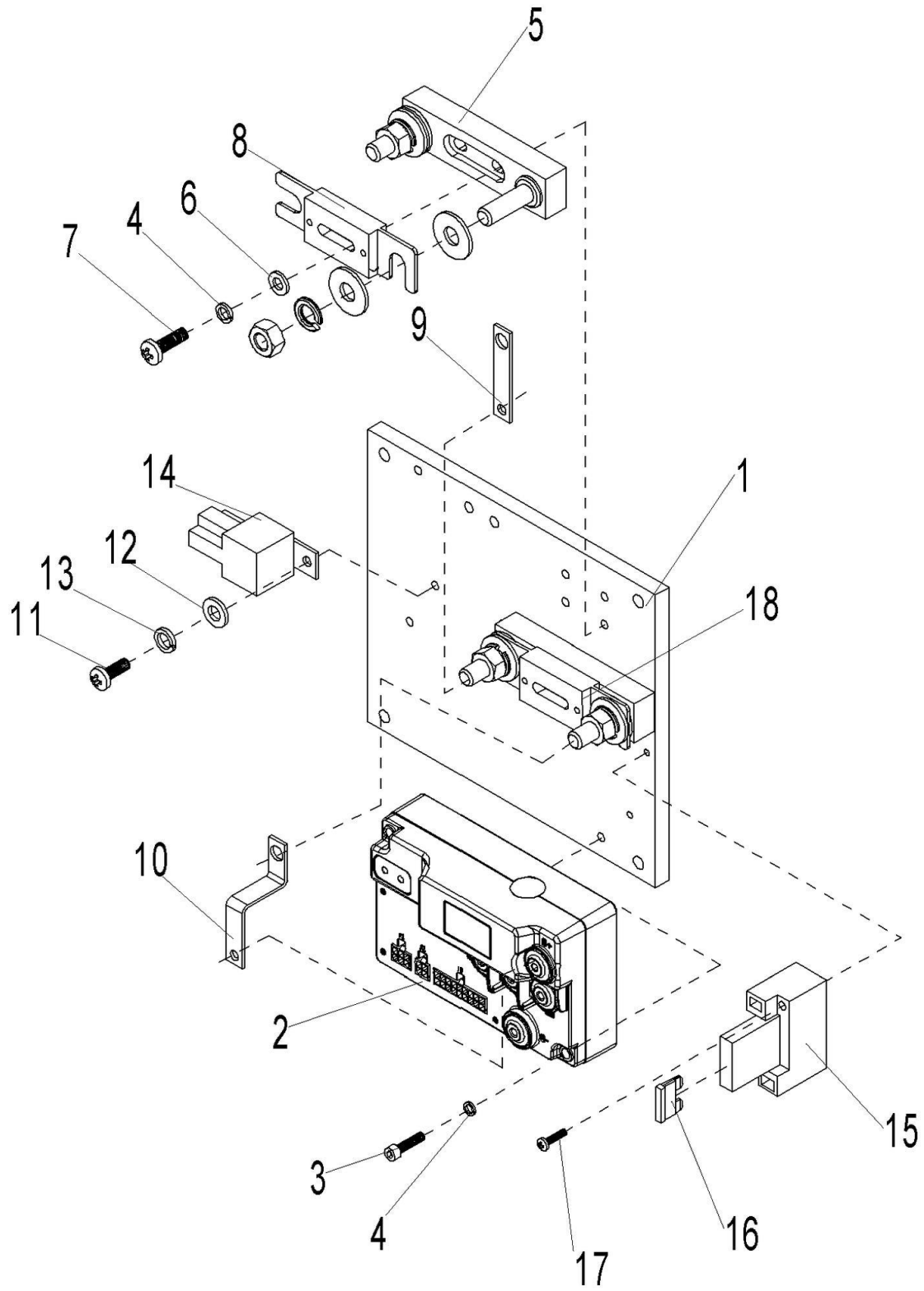

Fig. 18 Controller Components

No.	Art No.	Description	Qty.	Note
1	531833020001	Aluminium plate (ECL15)	1	
2	921400100093	Controller 1226BL-4153	1	
3	910200500030	Screw GB818-M4x40-4.8	2	
4	910400500003	Washer GB93-4	6	
5	920100400002	Fuse seat SYY	2	
6	910400100003	Washer GB97.1-4-200HV	4	
7	910200500024	Screw GB818-M4x16-4.8	2	
8	920100100006	Fuse 130A (Plastic)	1	
9	505633020003	Copper bar	1	
10	531833020000	Copper bar	1	
11	910200200032	Screw GB70.1-M6x10-8.8	1	
12	910400100005	Washer GB97.1-6-200HV	1	
13	910400500005	Washer GB93-6	1	
14	920800100010	Relay CMA36-S-DC48V	1	
15	920100400006	Fuse seat BD-1x10A	1	
16	920100200002	Fuse10A	1	
17	910200500017	Screw GB818-M3x30-4.8	2	
18	920100100004	Fuse 80A (Plastic)	1	

Fig. 19 Charger components

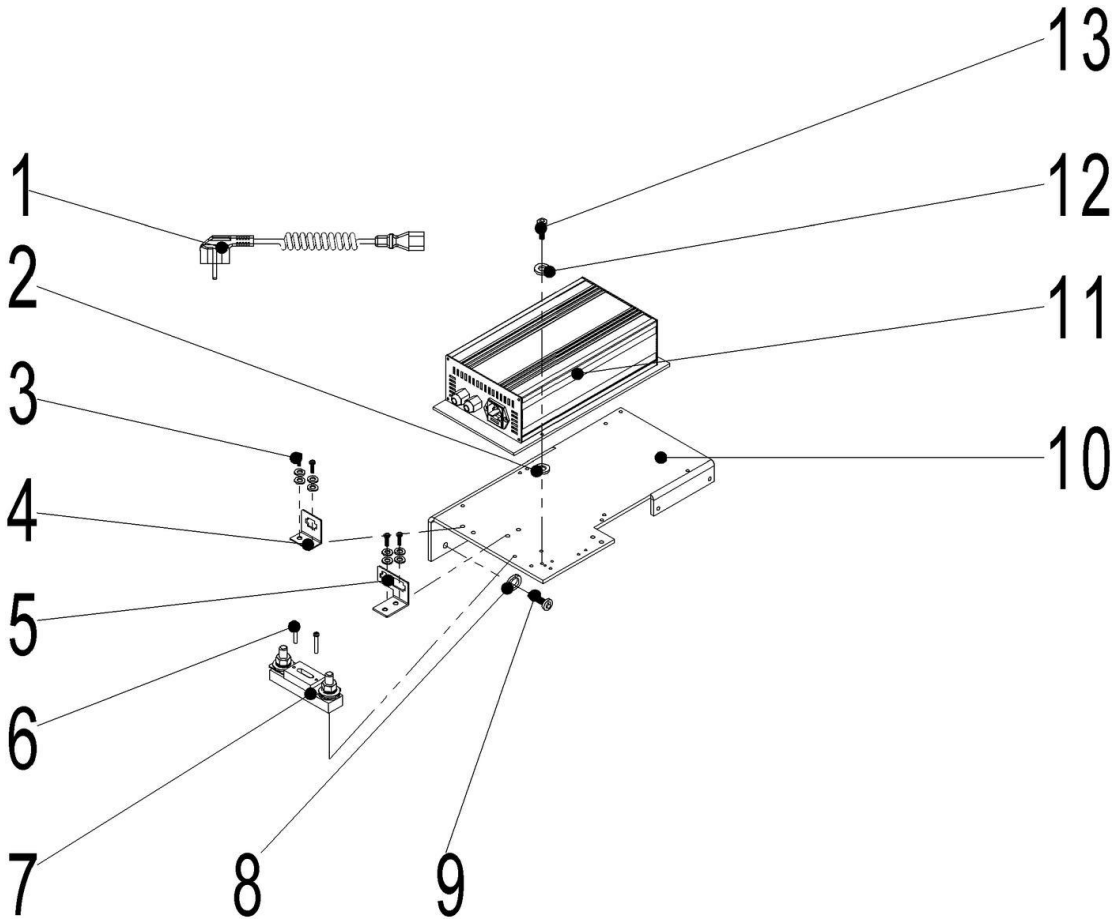

Fig. 19 Charger Components

No.	Art No.	Description	Qty.	Note
1	921500200003	Plug 3*0.75(AUS)	1	Option
	921500200004	Plug 3*0.75(ENG)	1	
	921500200005	Plug 3*0.75(EU)	1	
	921500200006	Plug 3*0.75(ITY)	1	
	921500200007	Plug 3*0.75(Sweden)	1	
	921500200002	Plug 3*0.75(US)	1	
	921500200008	Plug 3*0.75(Asia)	1	
2	950100200001	Pad	1	11.5X7.5X3
3	910200500037	Screw	4	M5x10
4	504121520021	Plug fixing frame	1	
5	921300300004	Plug fixing frame	1	
6	910200500024	Screw	2	M4x16
7	920100400002	Fuse seat SYY	1	
8	910400100004	Washer GB97.1-5-200HV	4	
9	910200200022	Screw GB70.1-M5x12-8.8	4	
10	532036520000	Charger fixing frame	1	
11	921000100054	Charger XL48V8A	1	
12	910400100003	Washer	4	
13	910200200014	Screw GB70.1-M4x12-8.8	4	

Fig. 20 wiring harness

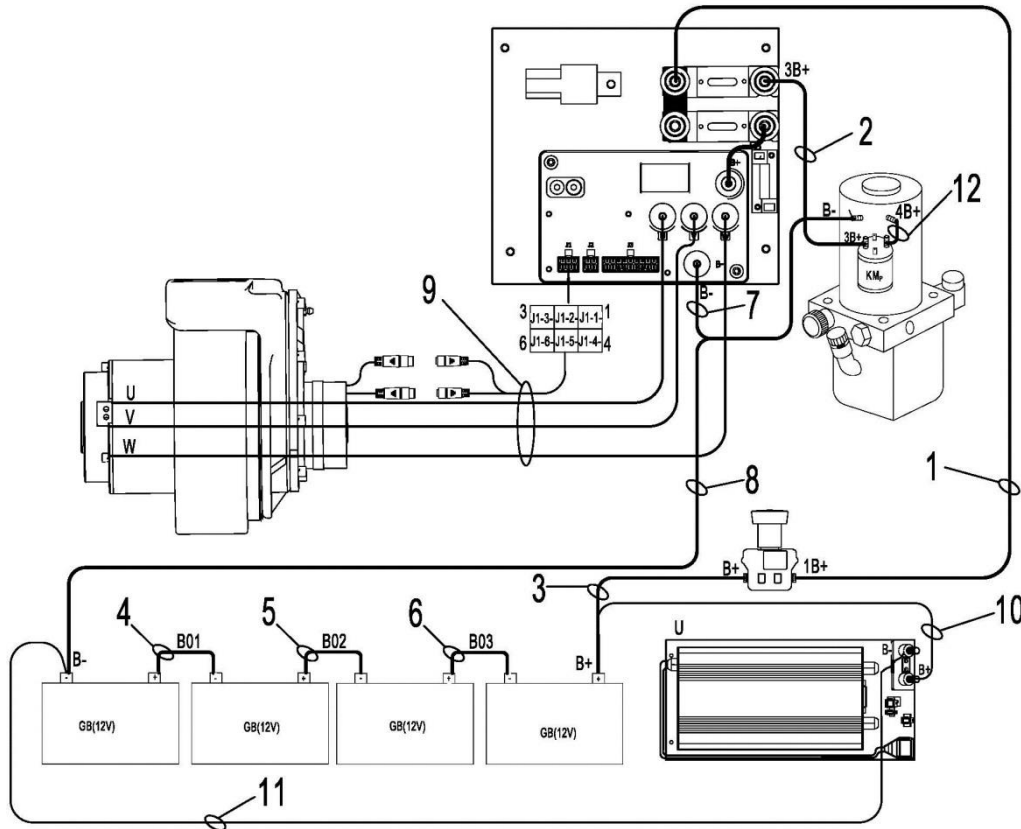

Fig. 20 Wiring Harness

No.	Art No.	Description	Qty.	Note
1	531833010003	Wiring harness -1B+-16-8-8-340	1	
2	531833010005	Wiring harness -3B+-16-8-8-460	1	
3	531833010006	Wiring harness -B+-16-6-8-1200	1	
4	531833010007	Wiring harness -B01-16-6-6-200	1	
5	531833010008	Wiring harness -B02-16-6-6-1250	1	
6	531833010009	Wiring harness -B03-16-6-6-120	1	
7	531833010010	Wiring harness -B--10-6-8-410	1	
8	531833010011	Wiring harness -B--16-6-8-750	1	
9	531833010014	Driving motor cable (ZD)	1	
10	531833010012	Linking cable -B+-2.5-6-8-1500	1	
11	531833010013	Linking cable -B--2.5-6-8-1380	1	
12	531833010019	Wiring harness -4B+-16-8-8-100	1	

Fig. 21 Sticker(for EU)

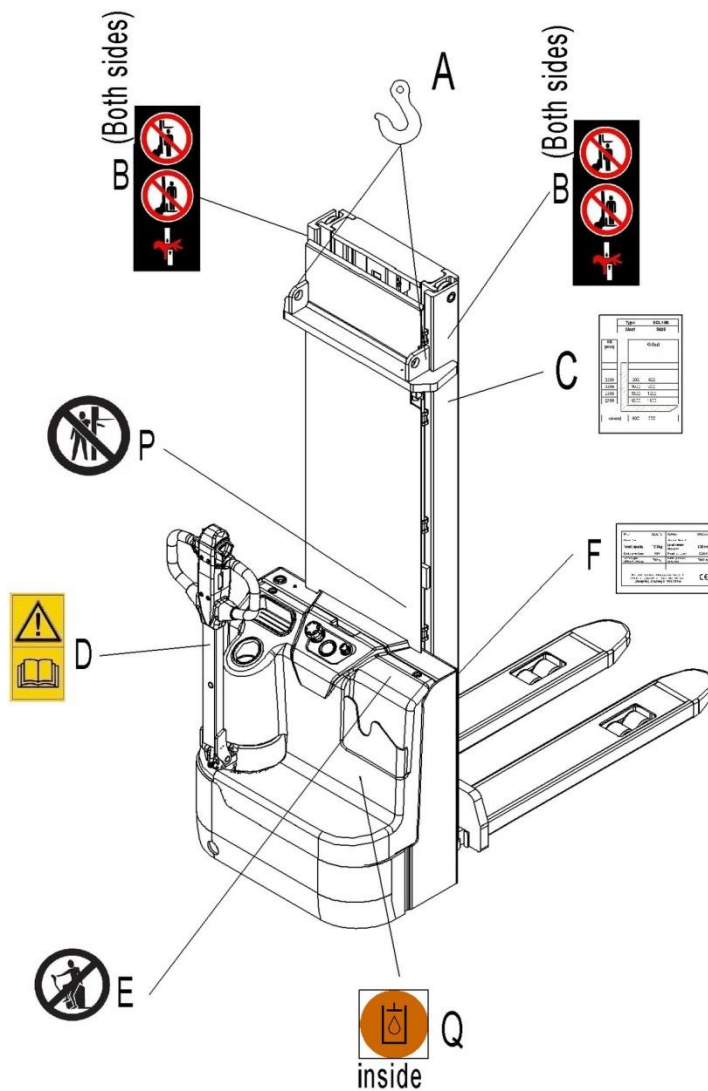

Fig. 21 Sticker

No.	Art No.	Description	Qty.	Note
A	941200300001	Crane hook label	2	
B	941200100004	Warning decal: Do not step under or on the forks	2	
C	531847520000	Residual lift capacity sticker	1	
D	941200300002	Sticker to read and follow these instructions	1	
E	941200100003	'No passengers' decal	1	
F	531847520001	CE label	1	
Q	941200300003	Filling sticker	1	
P	941200100006	Never reach through	1	

Fig. 22 Sticker(for US)

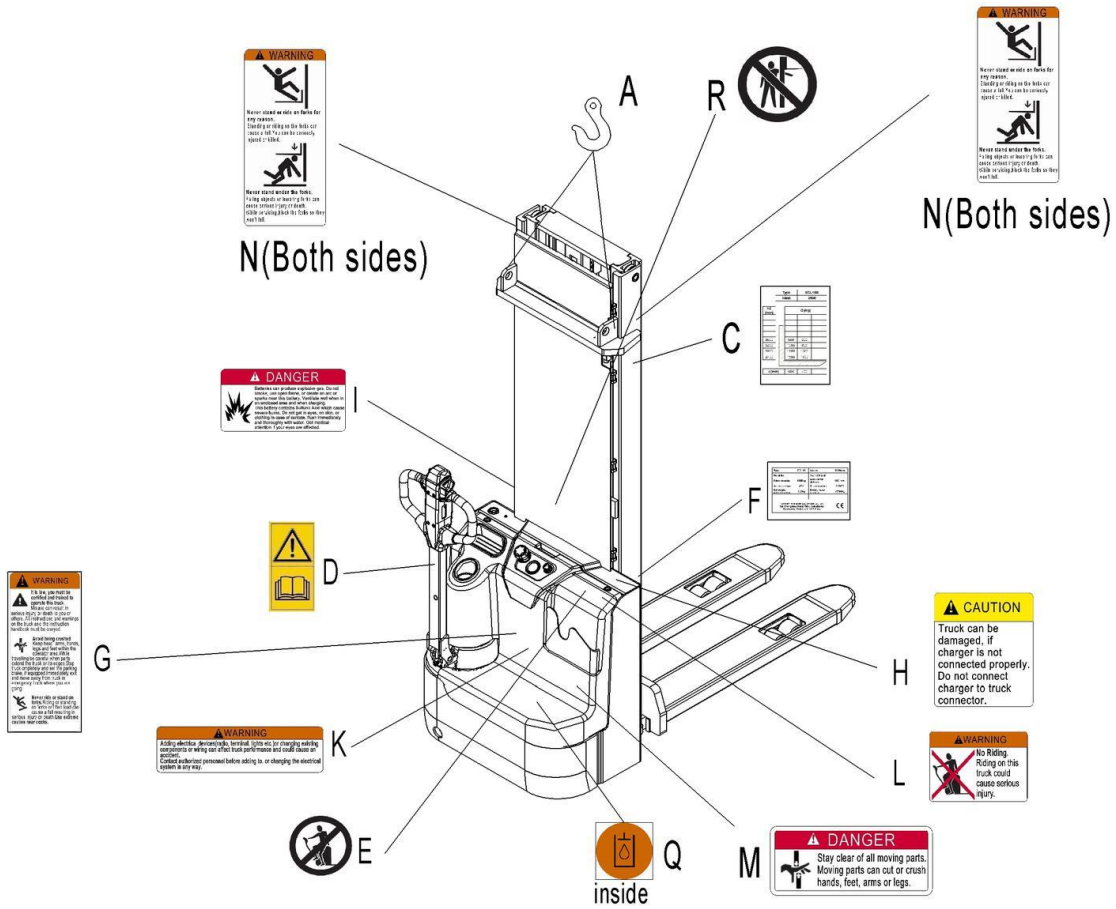

Fig. 22 Sticker(for US)

No.	Art No.	Description	Qty.	Note
A	941200300001	Crane hook label	2	
C	531847520020	Residual lift capacity sticker	1	
D	941200300002	Sticker to read and follow these instructions	1	
E	941200100003	'No passengers' decal	1	
F	531847520005	CE label	1	
G	941200100009	Warning label	1	
H	941200100012	Warning label	1	
I	941200100013	Warning label	1	
K	941200100010	Warning labe	1	
L	941200100011	Warning labe	1	
M	941200100014	Warning labe	1	
N	941200100016	Warning labe	2	
Q	941200300003	Filling sticker	1	
R	941200100006	Never reach through	1	

Easy worn parts list

No.	Art No.	Description	Qty.	Note
1	910700200019	Bearing GB276-6204-2RS	8	Load roller components
2	940300300005	Roller Φ 80x70 (Steel core PU)	4	
3	502398510002	Roller kits (tandem)	4	
4	910800400002	Dust ring	1	Cylinder components
5	535398520003	Support ring	1	
6	532698520002	O ring	1	
7	532698520003	Support ring	1	
8	532698520004	O ring	2	
9	532698520005	Y ring	1	
10	532698510001	Cylinder sealing components	1	
11	531898520014	Carbon brush	4	Hydraulic power unit components
12	910700200019	Bearing GB276-6204-2RS	2	Side roller components
13	940300300030	Roller Φ 100x50 (Steel core PU)	1	
14	910700600001	Bearing GB297-30205	1	
15	910700700011	Bearing GB301-51113	1	
16	532298510004	Side roller components	1	
17	940400100043	Air spring 800N (D327)	1	Tiller arm components
18	940500200005	Bushing (with shoulder) Φ 20x Φ 22x12-SF-1	2	
19	920200400033	Proximity switch AZ17M05PK15	1	
20	921700100018	Accelerator	1	Tiller head components
21	534311010008	Tiller micro switch components	1	
22	534311010007	Tiller micro switch components	1	
23	920200300001	Micro switch XZ-15GW22-B	1	Mast assembly (Two-stage mast)
24	920200400032	Proximity switch AZ17M05PB15	1	

25	920200300001	Micro switch XZ-15GW22-B	1	Mast assembly (One-stage mast)
26	920100400002	Fuse seat SYY	2	Controller components
27	920100100006	Fuse130A (Plastic)	1	
28	920100200002	Fuse10A	1	
29	920100100004	Fuse80A (Plastic)	1	
30	920100400002	Fuse seat SYY	1	Charger components